

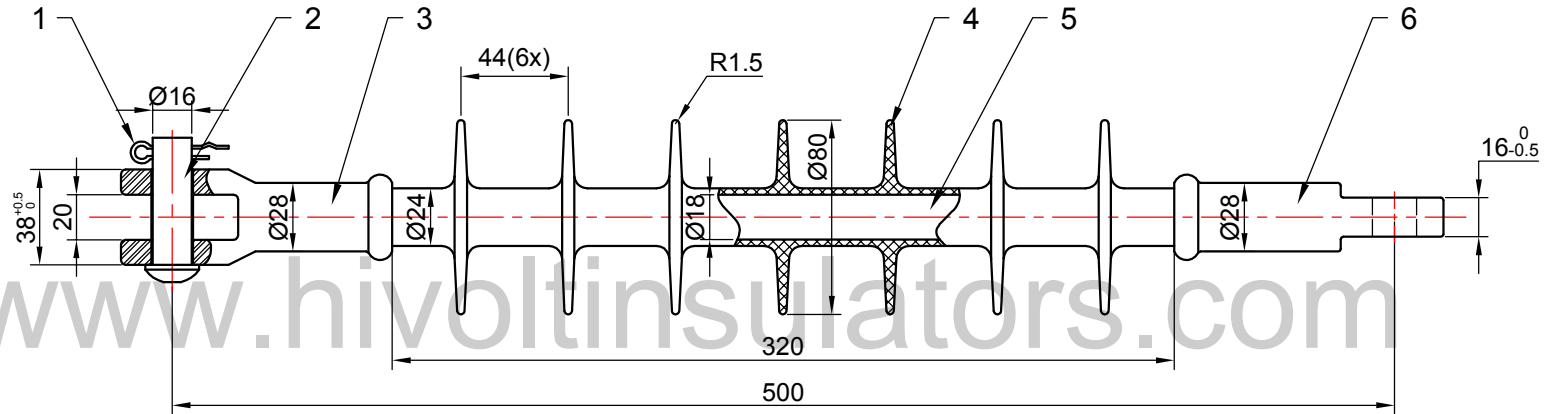

911810SH



TECHNICAL SPECIFICATIONS

- 1. Rated voltage 33kV
  - 2. Norminal creepage distance 660mm
  - 3. Dry arcing distance 340mm
  - 4. Power frequency flashover voltage Wet 120kV  
Dry 140kV
  - 5. Lighting impulse flashover voltage 235kV
  - 6. Tensile strength 70kV
  - 7. Torque strength 47Nm
- Standard: ANSI C29.13, IEC 1109

ITEM NO	DESCRIPTION	MATERIALS	QTY	REMARK
6	Tongue	Forged steel	1	Hot galvanizing
5	Core rod	Glass fiber reinforced epoxy resin	1	
4	Weather sheds	Silicone rubber		Colour: Grey
3	Clevis	Forged steel	1	Hot galvanizing
2	Clevis pin	Forged steel	1	Hot galvanizing
1	Cotter	Stainless steel	1	R-shaped

Material	Weight		Title	Drawing No.		
					HS018116	
	Date	Name	FXB-28/70 Composite insulator			
Drawn	2017-05-24	miaosongsong	UNIT	SCALE	COLOUR	
Checked			mm	1:3	Grey	
Approved			 DALIAN HIVOLT POWER SYSTEM CO.,LTD.			